

MAINTENANCE

FOR NAFCO RESIDENTIAL LUXURY VINYL TILE

Although NAFCO floors are durable, all floor coverings require some care to look their best. Many problems can be prevented before they occur. Special attention should be paid when selecting a floor for your specific needs.

The type and frequency of traffic on your NAFCO floor will determine the frequency of maintenance needed. The type of floor and even the color will also have some bearing on how much care may be necessary. For example, solid color floors will visually show scuff, scratches, dirt and general wear to a greater degree than multi-colors of chips or patterns. Of course, white or light colors will visually show staining to a greater degree than darker colors. For this reason, solid color and white floors should receive special attention in regard to preventive maintenance and the amount of care provided. Good judgement when choosing the type and style of your new floor will help prevent maintenance problems before the floor is even installed.

If DOMCO TARKETT 400 or DOMCO TARKETT 850 adhesives were used when installing your floor, all traffic and furniture should stay off the floor for at least 24 hours to allow the adhesive to dry completely.

Quik-Stik tiles or DOMCO TARKETT 800 adhesive installations may be walked upon immediately after completion.

NOTE: DO NOT WASH ANY INSTALLATION FOR 48 HOURS!

Here are the proper steps for maintaining your NAFCO floor:

1. In order to prevent indentations and scratches, use glass, polished metal or other non-staining cups or casters with flat under surfaces (see diagrams on page 25).
2. Protect your floor against burns. NAFCO floors can be damaged by burns from the glowing end of a cigarette, matches, or other extremely hot items.
3. Protect your floor from tracked-in dirt and grit particles by using mats at all outside entrances. Take the time to remove any imbedded grit particles from shoe soles before entering the room. Avoid the use of rubber or latex-backed mats, as certain rubber compounds can permanently stain vinyl (consult the mat manufacturer to determine if their backing will stain vinyl). Avoid tracking in tar or asphalt from driveways, as this can also discolor vinyl.
4. Avoid stiletto or damaged high heels on your floor. They can cause permanent damage.
5. All NAFCO floors have good resistance to stains. They are not affected by most common household spills; however, any spill should be cleaned up immediately. The longer the spilled material is left on the floor, the greater the risk of permanently staining the floor. For information regarding the proper method or solution to use on a specific stain, see the chart on page 28.
6. Avoid exposure to direct sunlight for prolonged periods, as this can result in tile discoloration. Excessive temperatures might cause tile expansion. During peak sunlight hours, the use of drapes or blinds is recommended especially on patio doors, etc., that receive direct sunlight.

Preventive Maintenance for all NAFCO Residential Floors

Light daily sweeping or vacuuming will prevent dirt and grit particles from being ground into the surface of the floor. If the floor is swept daily, a light weekly washing should be sufficient. Initially, damp mopping with clear water may be all that is necessary under light traffic conditions. After the first week or so, it will be necessary to use DOMCO TARKETT SureShine® cleaner. Apply the SureShine® cleaner to the floor with a sponge mop. After the soil deposits have been loosened from the floor, mop thoroughly with clean water to remove them and all detergents, then rinse the floor with clean, warm water to remove all soapy residue. Do not flood the floor with water. Any detergent film left on the floor can hold tracked-in dirt and leave the surface with a dull, cloudy appearance.

NAFCO's factory Tritonite™ finish is resistant to scuffing, wear from normal use, and common stains. However, the finish is not indestructible and will scratch when subjected to harsh conditions.

NAFCO residential tiles have a surface factory finish top coat. The finish is applied during the manufacturing process and is either high gloss or matte satin, depending upon the product style. All gloss levels are maintained in the same way (see page 27).

In time, high traffic areas may begin to show a reduction in gloss. When this occurs, thoroughly clean and dry the floor and apply a light coat of DOMCO TARKETT SureShine® Polish. To apply DOMCO TARKETT SureShine® Polish, pour the liquid in a shallow pan; dip in a sponge mop and wring it out gently, leaving it saturated with the liquid polish. Mop in one direction to insure uniform distribution. Do not mop too vigorously as this could cause bubbles.

Continue to apply DOMCO TARKETT SureShine® Polish to the floor until the entire floor is evenly coated. SureShine® Polish dries in 20-30 minutes; if more than one coat is desired, be sure to let each coat completely dry before applying another. **Keep in mind that 2-3 thin coats are better than one heavy coat.**

In time, it may be necessary to strip the old layers of DOMCO TARKETT SureShine® Polish and apply fresh coats. Strip the polish by using a high-quality wax/polish remover.

Important To The End User:

Information concerning installation and maintenance for NAFCO floors is provided in each product carton. This must be passed on to the end user upon completion of each installation.

MAINTENANCE

FOR NAFCO LUXURY VINYL TILE IN LIGHT COMMERCIAL APPLICATIONS

Although NAFCO floors are durable, all floor coverings require some care to look their best. Many problems can be prevented before they occur. Special attention should be paid when selecting a floor for your specific needs.

The type and frequency of traffic on your NAFCO floor will determine the frequency of maintenance needed. The type of floor and even the color will also have some bearing on how much care may be necessary. For example, solid color floors will visually show scuff, scratches, dirt and general wear to a greater degree than multi-colored chips or patterns. Solid color and white floors should receive special attention in regard to preventive maintenance and the amount of care provided. Good judgement when choosing the type and style of your new floor will help prevent maintenance problems before the floor is even installed.

If DOMCO TARKETT 400 or DOMCO TARKETT 850 adhesives were used when installing your floor, all traffic and furniture should stay off the floor for at least 24 hours to allow the adhesive to dry completely.

Quik-Stik tiles or DOMCO TARKETT 800 adhesive installations may be walked upon immediately after completion.

NOTE: DO NOT WASH ANY INSTALLATION FOR 48 HOURS!

Here are the proper steps for maintaining your NAFCO floor in a light commercial application:

1. In order to prevent indentations and scratches, use glass, polished metal or other non-staining cups or casters with flat under surfaces (see diagrams on page 25).
2. Protect your floor against burns. NAFCO floors can be damaged by burns from the glowing end of a cigarette, matches, or other extremely hot items.
3. Protect your floor from tracked-in dirt and grit particles by using mats at all outside entrances. Take the time to remove any imbedded grit particles from shoe soles before entering the room. Avoid the use of rubber or latex-backed mats, as certain rubber compounds can permanently stain vinyl (consult the mat manufacturer to determine if their backing will stain vinyl). Avoid tracking in tar or asphalt from driveways, as this can also discolor vinyl.
4. Avoid stilleto, damaged high heels, or sharp objects dropped on your floor. They can cause permanent damage.
5. All NAFCO floors have a good resistance to stains and are not affected by most common household spills. However, any spill should be cleaned up immediately. The longer the spilled material is left on the floor, the greater the risk of permanently staining the floor. For information regarding the proper method or solution to use on a specific stain, see the chart on page 28.
6. Avoid exposure to direct sunlight for prolonged periods, as this can result in tile discoloration. Excessive temperatures might cause tile expansion. During peak sunlight hours, the use of drapes or blinds is recommended especially on patio doors, etc., that receive direct sunlight.

Preventive Maintenance for all NAFCO Light Commercial Applications

Light daily sweeping or vacuuming will prevent dirt and grit particles from being ground into the surface of the floor. If the floor is swept daily, a light weekly washing should be sufficient. The type and frequency of traffic will determine the frequency of maintenance needed. It will be necessary to use DOMCO TARKETT SureShine® cleaner. Apply the SureShine® cleaner to the floor with a sponge mop. After the soil deposits have been loosened from the floor, mop thoroughly with clean water to remove them and all detergents, then rinse the floor with clean, warm water to remove all soapy residue. Do not flood the floor with water. Any detergent film left on the floor can hold tracked-in dirt and leave the surface with a dull, cloudy appearance.

NAFCO's factory Tritonite™ finish is resistant to scuffing, wear from normal use, and common stains. However, the finish is not indestructible and will scratch when subjected to harsh conditions or sharp objects.

NAFCO tiles have a surface factory finish top coat. The finish is applied during the manufacturing process and is either high gloss or matte satin, depending upon the product style. All gloss levels are maintained in the same way (see page 27).

In time, high traffic areas may begin to show a reduction in gloss. When this occurs, thoroughly clean and dry the floor and apply a light coat of DOMCO TARKETT SureShine® Polish. To apply DOMCO TARKETT SureShine® Polish, pour the liquid in a shallow pan; dip in a sponge mop and wring it out gently, leaving it saturated with the liquid polish. Mop in one direction to insure uniform distribution. Do not mop too vigorously as this could cause bubbles.

Continue to apply DOMCO TARKETT SureShine® Polish to the floor until the entire floor is evenly coated. SureShine® Polish dries in 20-30 minutes; if more than one coat is desired, be sure to let each coat completely dry before applying another. **Keep in mind that 2-3 thin coats are better than one heavy coat.**

In time, it may be necessary to strip the old layers of DOMCO TARKETT SureShine® Polish and apply fresh coats. Strip the polish by using a high-quality wax/polish remover.

Important To The End User:

Information concerning installation and maintenance for NAFCO floors in a light commercial application is provided with each product. This information must be passed on to the end user upon completion of each installation.

MAINTENANCE

FOR NAFCO BEST LIVING FLOORS IN COMMERCIAL APPLICATIONS

NAFCO Best Living Series may be installed in conventional commercial environments. When this is done, we recommend a commercial-type maintenance procedure along with appropriate commercial maintenance products. DOMCO TARKETT does make available commercial grade floor maintenance products: a neutral cleaner, floor stripper, and floor polish in normal, matte and gloss versions. We recommend you use DOMCO TARKETT maintenance materials or products of equal quality for maintaining NAFCO Commercial Floorings.

When used commercially NAFCO Best Living products should be maintained with floor polish. After initial deep cleaning, the floor is then coated with 2-3 coats of polish. Subsequent maintenance should involve consistent dirt removal, damp mopping when needed, and spray buffing followed by an occasional re-coat of floor polish. At least once or twice a year, the floor should be stripped of all polishes and re-coated as a new floor. These procedures will help to ensure the beauty and durability of your NAFCO floor.

Maintaining Commercial Areas

All vinyl flooring requires effective cleaning and maintenance to ensure its durability, appearance, and safety. How frequently the floor must be maintained depends largely on the amount and type of traffic and the amount and frequency of soiling.

The type of floor and the color are also important. For example, solid-colored floors will show scuffs, scratches, dirt, and general wear more than multi-colored patterns. Likewise, lighter colors will show marks more than darker colors.

Although DOMCO TARKETT can make general recommendations, the local conditions will determine what specific maintenance is needed. It is the responsibility of the maintenance contractor to set up a maintenance program that meets the needs of the facility. For example, requirements in a 12th floor office suite will be significantly different from those in a supermarket or a restaurant dining area. An effective maintenance program should include:

1. Thorough dirt and grit regulation;
2. Prompt removal of spills and staining material; and
3. Protection of the floor surface.

There have been many improvements in chemical maintenance products, cleaning and buffing pad composition, maintenance machines and procedures. Intensive training programs by nationally known maintenance product manufacturers have significantly improved the expectations for overall protection and appearance of all vinyl tile floors. At the same time, cost per square foot for caring these floors in commercial areas has gone down. High quality maintenance of vinyl flooring is now easier than ever before.

Initial Deep Cleaning Procedure

1. Consult and follow application instructions on product labels.
2. Dust mop entire floor area and remove gum, tar, glue, etc. from floor.
3. Mix 4-6 ounces of DOMCO TARKETT Commercial Floor Cleaner with each gallon of warm water.
4. Dip mop in cleaning solution, let excess solution drain off and apply cleaner liberally to floor. Let cleaner set on floor several minutes before scrubbing. DO NOT FLOOD FLOOR.
5. Important: With blue or green pad or equivalent bristle brushes, pass over each tile section at least twice. Do not rush this procedure, it is crucial. If necessary, apply more solution to keep floor wet so that is wet at all times during the deep scrub procedure. Do not let solution dry under any conditions.
6. After a section is deep scrubbed, pick up the cleaning solution immediately with an automatic scrubber or clean mop with clear water. Rinse the floor clean and allow to dry.

STAIN REMOVAL INFORMATION

How to Remove Stains from Your NAFCO Floor:

1. If a spill is fresh, wipe it up immediately using a blotting action with a paper towel. Wash and rinse.
2. If the stain has set, remove it with a plastic spatula or something equivalent that will not scratch or damage the floor surface. Wash and rinse.
3. Wash the stain with a clean, white cloth dipped in clear water. Repeat several times, turning the cloth frequently.
4. Wash the stain with a clean, white cloth dipped in a mild solution of DOMCO TARKETT SureShine® Cleaner. Rinse well.
5. Wipe the stain with a clean, white cloth moistened with full strength DOMCO TARKETT SureShine® Cleaner. Rinse well.
6. Lightly moisten a clean, white cloth with lighter fluid, taking all necessary precautions against fire, and wipe over the stains. Do only a small area at a time. When dry, wash with DOMCO TARKETT SureShine® Cleaner. Rinse well.
7. Rub the stain with a nylon pad (the type used for cleaning non-stick pots and pans) dampened with full strength DOMCO TARKETT SureShine® Cleaner.
8. Dust the stain with household cleansing powder and rub lightly with a nylon pad (the type used for cleaning non-stick pots and pans) or with a clean, white cloth dampened in a mild solution of DOMCO TARKETT SureShine® Cleaner.
9. Rub the stain gently with a clean, white cloth dampened lightly with alcohol, taking all necessary precautions against fire. Do only a small area a time. When dry, wash with DOMCO TARKETT SureShine® Cleaner. Rinse well.
10. Do not walk on the treated area until it is completely dry. Buff.

For tough stains or dirt build-up, we recommend a high-quality wax/polish remover. Follow the recommended procedures from the manufacturer.

STAIN REMOVAL CHART

Here are some of the most common household stains and their recommended removal procedures. Refer to procedure numbers above.

Stain	Procedures To Use
Tar, grease, oil	2, 5, 6, 10
Candle wax, chewing gum	2, 5, 8, 10
Rubber heel marks, shoe polish	7, 8, 10
Coffee stains, alcohol	1, 4, 10
Beverages, fruit juice, ink, iodine, mustard, keetchup	7, 8, 10
Cigarette burns, rust, mildew, dye, blood, grass	7, 8, 10
Paint, varnish, solvents	1, 5, 10 or 7, 8, 10
Shellac	1, 5, 10 or 2, 7, 8, 10
Nail polish, lacquer, nail polish remover, dry cleaning fluids	1, 5, 10 or 2, 7, 8, 10
Acids, alkalis, lye, drain cleaners, strong soaps, cleaners, detergents	1, 3, 7, 10

Apply Floor Finishes

1. Pour DOMCO TARKETT Commercial Floor Polish into clean mop buckets.
2. Use new properly prepared or clean mops for applying floor finish.
3. Dip mop in floor finish, place mop in wringer and tamp lightly. The mop should be full but not dripping.
4. Apply the 2-3 thin coats of finish to floor. Under normal conditions, allow a minimum of 45 minutes drying time between coats. Ensure adequate drying time between coats. One or two additional thin coats of finish should be applied prior to opening the building for use.
5. Important: AC/Heat must be in operation to assure adequate drying time and curing of finish between coats. Temperature and humidity levels in the building will determine drying time.

CAUTION: Do not dry buff, spray buff, or burnish vinyl composition tile or asphalt tile floors without prior applications of an acrylic finish, which is resistant to neutral cleaners. Do not dry strip under any conditions. If followed closely, these procedures will prevent costly delays and unnecessary expenses.

Spray Buffing

Spray buffing is a common and effective method of commercial maintenance. If desired, this may be done by attaching a spray applicator or using a hand-held spray applicator and lightly spraying diluted DOMCO TARKETT Commercial Floor Polish (1 part polish to 3 parts warm water) or a commercially-formulated spray buff solution onto the floor. Buff the solution in before the liquid can dry. A thin, protective, glossy film remains after buffing the liquid dry, leaving the base coats intact and reducing the need for stripping. High traffic areas may require refresher coats more frequently.

CAUTION: Make sure the power buffer is in good condition and may be used on wet floors safely. Make sure there is no exposed wiring and no danger from electrical shock.

GENERAL RECOMMENDATIONS

For Tables and Heavy Furniture Not Frequently Moved:

In order to prevent indentations and scratches, use glass, polished metal or other non-staining cups or casters with flat under surfaces. Flat under surfaces should not be less than 2" diameter for the legs of tables and heavy furniture or appliances. They are made with neutral colors and with openings of varying square and round sizes.

NOTE: Some factory installed rolling-type casters on furniture and appliances can damage resilient flooring. The suitability of using these casters rests solely with the furniture or appliance manufacturers; NAFCO does not warrant such items.

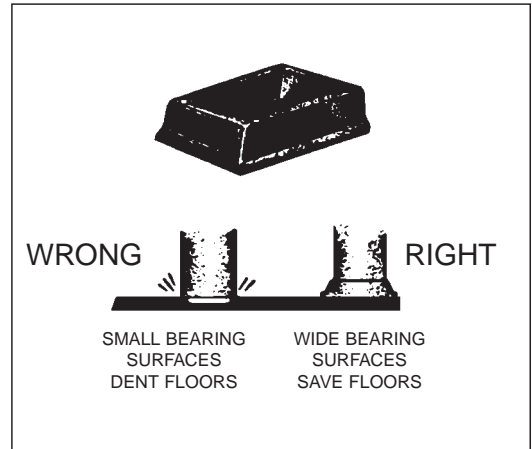

For Desk Chairs and Other Rolling Furniture:

Broad surface, non-staining casters or large diameter wheels (2" or more) should be used on office-type desk chairs or other rolling furniture. Wide, flat and soft non-staining rubber composition tread wheel casters or flat glides are recommended. Small diameter or narrow, hard wheel casters, particularly with a crowned tread and without ball swivels will unnecessarily and unduly mark resilient flooring. Consult your flooring contractor regarding the moving of heavier furniture, such as pianos, hand trucks, hospital beds, etc.

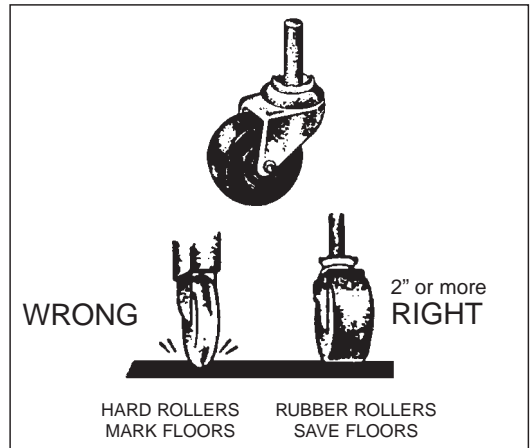

For Straight Chairs, Small Cabinets, Bar Stools, etc:

Flat, polished metal glides that have bearing surfaces not less than 1" diameter should be used on straight chairs, bar stools, etc. These glides should have rounded edges and a flexible pin to maintain flat contact with the floor. Small metal domes should be removed from the bottoms of all chair legs and replaced with the correct glides as mentioned.

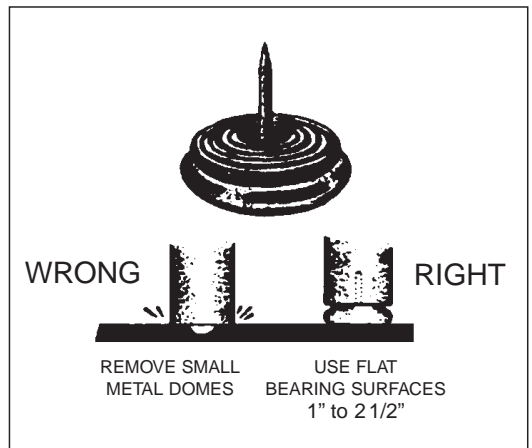

Note:

The use of felt pads is NOT recommended because felt can trap dirt, sand, or other foreign matter and that can scratch your flooring from the movement of the chair and result in premature wear.



The following reference chart is a handy quick-guide on the DOMCO TARKETT maintenance products specially formulated for all NAFCO Flooring products. Detailed maintenance for each product type should be followed in conjunction with this chart.

DOMCO TARKETT

Residential Floor Care Products

	* FLOOR POLISH	NO RINSE CLEANER
Product	DOMCO TARKETT SureShine® Polish Long-Lasting, High Gloss & Matte Satin	DOMCO TARKETT SureShine® No-Rinse Cleaner
Product Codes*	F210 High Gloss F200 Matte Satin	F230
Use	Specially formulated by DOMCO TARKETT for use on NAFCO residential vinyl flooring. Recommended for use on all residential flooring	Specially formulated by DOMCO TARKETT for use on NAFCO residential flooring. Recommended for use on all residential flooring
Size/Packaging	Quart (0.946 Liter) 12 per carton	Quart (0.946 Liter) 12 per carton
Weight per Carton	29 lbs. (13.2 kg)	29 lbs. (13.2 kg)
Warning	<ul style="list-style-type: none"> • Do not take internally. • Keep out of reach of children. 	<ul style="list-style-type: none"> • Eye irritant. • Do not take internally. • Keep out of reach of children. • Do not use on solid wood or cork floors.
Features	<ul style="list-style-type: none"> • High & Matte Satin gloss acrylic polishes for desired look. • High solids content for excellent shine, protection & durability. • Self-leveling for easy application. • Detergent & abrasion resistant. • Matte Satin preserves natural appearances of NAFCO's stone & wood-look planks. 	<ul style="list-style-type: none"> * No-Rinse for No-Wax floors. • Neutral pH detergent. • Dilute to as low as 1/4 cup per gallon of water. • Easy to use.
Coverage	375-500 sq. ft. per quart	Up to 8 gallons per quart of concentrate

*Be certain that you choose the proper gloss level for your NAFCO flooring (high or matte satin gloss).

DIRECTIONS FOR USE

	FLOOR POLISH	NO RINSE CLEANER
Directions	<p><u>FLOOR PREPARATION:</u></p> <ul style="list-style-type: none"> Sweep or vacuum thoroughly. Wash with SureShine® No-Rinse Cleaner for no-wax floors. Let dry completely. <p><u>POLISH APPLICATION:</u></p> <ul style="list-style-type: none"> Apply a uniform coating using a damp sponge mop or polish applicator. Try not to move the polish applicator over any portion of the floor more than once per coat. Allow at least 30 minutes between coats. On initial application, or after stripping, always apply at least 2-3 thin coats of SureShine® Polish. Apply additional coats of polish as needed to maintain an acceptable level of appearance. <p><u>STRIPPING:</u></p> <ul style="list-style-type: none"> SureShine® strips easily when using SureShine® Cleaner & Wax Remover. Always rinse thoroughly with clear water after stripping. Stripping should only be done as needed. 	<p><u>DAMP MOPPING:</u></p> <ul style="list-style-type: none"> Use one cap full per gallon of water. Rinsing is not required. <p><u>WASHING:</u></p> <ul style="list-style-type: none"> Use 4-6 oz. per gallon of water. Apply the cleaning solution liberally to a portion of the floor and allow it 1-2 minutes to soak. Using a mop or scrub brush, scrub the area, then take up the excess solution. Immediately rinse with clear water. Allow to dry thoroughly.

All resilient floors need a regular cleaning program to retain a like-new appearance. The type and amount of traffic your floor receives will determine the frequency of maintenance.



No-Rinse Cleaner

SureShine® No-Rinse Cleaner for No-Wax Floors is a nearly neutral pH detergent designed for use at fairly high dilutions. It is low foaming, and won't attack floor polish. It can be diluted to as low as 1/4 cup per gallon of water.



Polish - Long-lasting, High Gloss

SureShine® High Gloss Polish is a high durability acrylic polish for restoring shine to residential floors. It contains 21% solids for excellent shine and protection, and is self leveling for easy application.



Polish - Long-Lasting, Matte Satin

SureShine® Matte Satin Polish is a high durability acrylic polish for restoring a satin lustre finish to residential floors. It has balanced weight for an excellent finish, and is self leveling for easy application.

All of these products have been specially formulated to be compatible with NAFCO Residential Flooring.

MSDS sheets are available for each of the maintenance and adhesive products and may be obtained by faxing a request to NAFCO Installation Services Department at 256-718-5277.

Note: If NAFCO Best Living products are used in commercial applications then commercial installation and maintenance guidelines must be followed.

MAINTENANCE FOR WALL BASE

This product has a non-porous solid vinyl wear surface that makes cleaning easy. Simply damp wipe with a soft cloth to remove light dirt and dust. Mild detergent and water may be necessary to clean areas that become severely dirty.

A cloth dampened with rubbing alcohol will help in removing scuff marks. Any excess adhesive that gets on the wall base surface during installation should be removed with soapy water. After the adhesive begins drying, a cloth dampened in mineral spirits may be necessary to remove it.

Avoid impact of wall installations with heavy maintenance equipment (floor buffing machines). This type of abuse/accidents can result in severe scuffing, gouging, and general surface damage.

The above-listed procedures apply to all NAFCO Supreme Wall Base solid colors.